

work in silence.

BORG

Frenchy

CONCEPT

DESIGN BY MARTIN SAAR

Frenchy was born from an idea of how the real french looks like. It rolls around the floor as elegantly as a slender french woman strolls around the boulevards. It's round body is just like the beret sitting on top of that that woman's perfectly done hair. Just like that mysterious french woman, it has many sides to its

characters, from a standard ottoman to a seat with castors, back and hand rests, topping off with a big mushroomy side table.



Frenchy

Materials used

- Frame: birch plywood
- Seat: HR foam
- Table top: painted MDF
- Legs: soft castors
- Table legs: concealed legs



ARMCHAIR

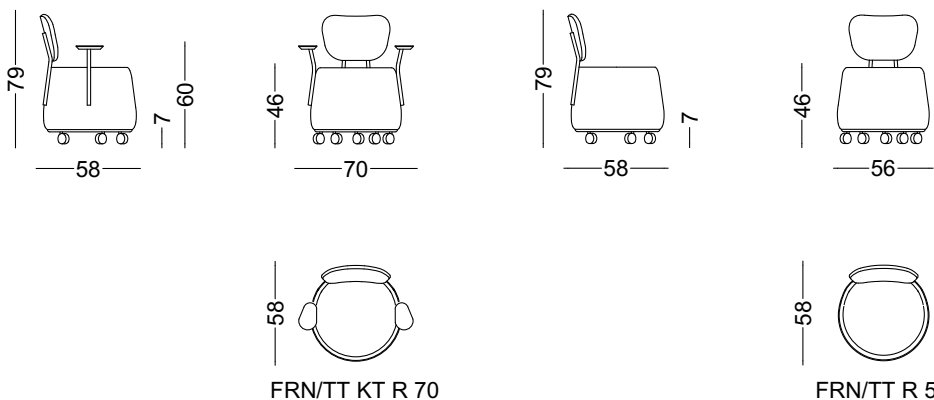

OTTOMAN



TABLE

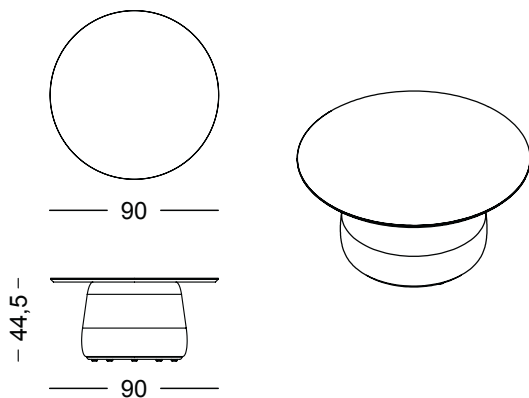

work in silence.
BORG